

Railway systems and their transition  
Lecture 4

# Railway Assets Rolling Stock.

Peter Kummer  
EPFL, Autumn Semester 2025  
September 30, 2025



# Railway Assets.

## Agenda.



Part 1  
«Heavy Assets»  
last week



Part 2  
«Rolling Stock»  
today



Part 3  
«Traffic Management Systems»  
in two weeks  
(next week: excursion)



# Case Study Railway Assets.

Student pitch

Railway systems and their transition  
Lecture 4

# Railway Assets Rolling Stock.

Peter Kummer  
EPFL, Autumn Semester 2025  
September 30, 2025



# Agenda.

1. Introduction
2. Technical aspects
3. Rolling stock conceptualisation
  1. Service Design
  2. Trade offs in rolling stock conceptualisation
4. Acquisition and life cycle management
  1. Acquisition
  2. Life cycle management (LCM)
5. Conclusion
6. Case study



# 1. Introduction.

What is rolling stock?

# Rolling stock definition. By Eurostat.

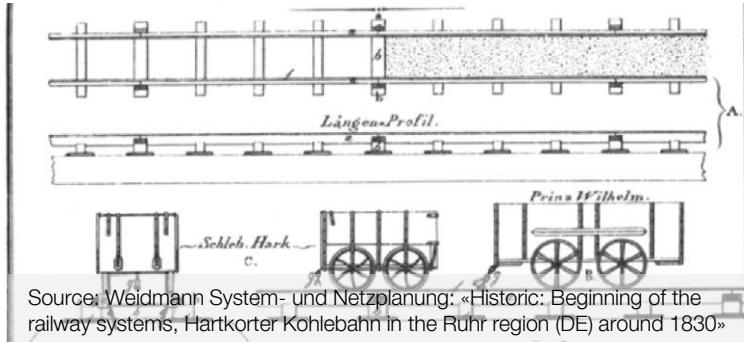

[1]: Railway vehicles that move exclusively on rails or a tracked transport system ...



[2] The term includes all powered (for example locomotives) ...



[3] and unpowered vehicles (for example passenger carriages or coaches) ...



[4] and goods wagons ...



[5] Etc. ... (electric multiple unit)



[6] Etc. II ... (special vehicles)

# Historical evolution (I). Technology.

**1847**



30km/h    125kW  
D 1/3 «Limmat»

**1904**



100km/h    1000kW  
A 3/5

**1927**



100km/h    2300kW  
Ae 4/7

**1952**



125km/h    4300kW  
Ae 6/6

**1991**



200km/h    6100kW  
Re 460 (Lok 2000)

**2010**



200km/h    7500kW  
RABe 502 (FV-Dosto)

Relation: 100kW = 136 HP

Source: Swiss locomotive and railcar classification - Wikipedia

## What factors drive the evolution of rolling stock? Technology? Yes, but ...



# Historical evolution (II). Speed.

High speed railway in Europe (TGV, 1981-2025)



Source: CRRC stellt den Prototyp des Hochgeschwindigkeitszuges CR450 vor, der eine Betriebsgeschwindigkeit von 400 km/h erreichen soll | Neueste Eisenbahn Nachrichten

“CRRC unveils the prototype of the CR450 high-speed train to reach an operating speed of 400 km/h” (2025)

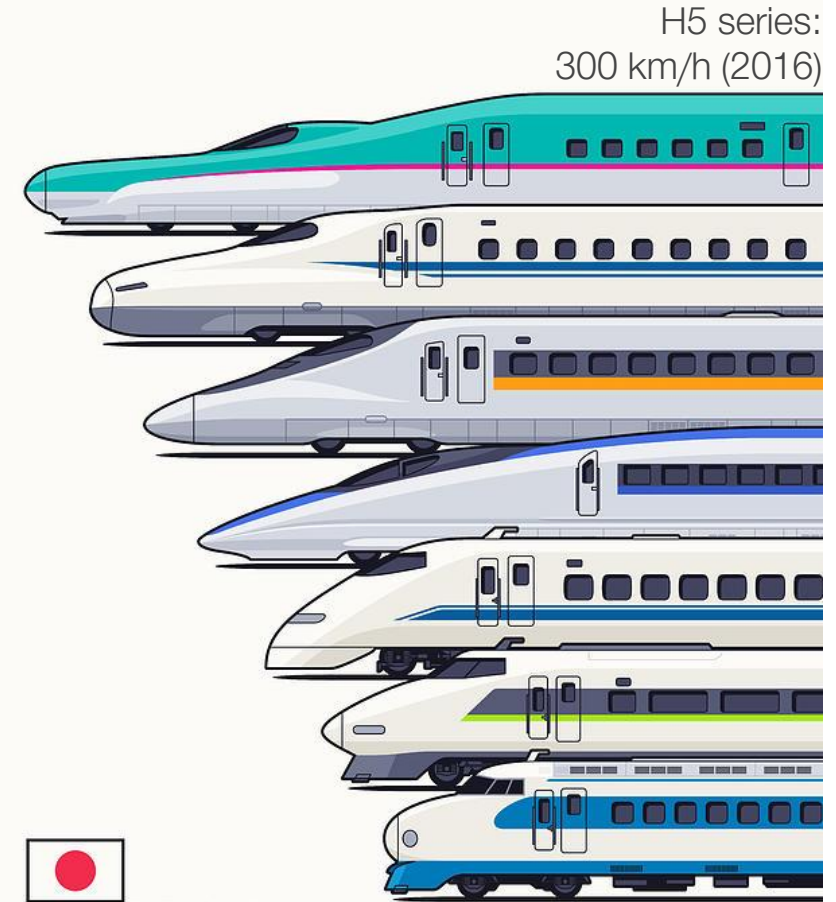

Source: Shinkansen Bullet Train Evolution - White Digital Art by Organic Synthesis - Fine Art America

# Historical evolution (III).

Hypothesis capacity.



138 seats, commuter train in Zurich (1950s)



1'070 seats, RV-Dosto RABe 511 (2010s)



105 seats, Turbo GTW (2010s)

# Is faster, stronger, and bigger always better? (Excursus).

A cross-industry comparison.

## Concorde (1962, speed)

First super sonic passenger airplane

Nationalistic fantasies about future export strengths, an ill-informed public debate and political deceit all masked the economic disaster that was Concorde



The Guardian

Source: Concorde was the flying Brexit: a different era but the same mistakes | Science | The Guardian

The British assembled pre-production Concorde 01 taking its maiden flight 17 December 1971. Photograph: PA

### How Boeing's 747 Revolutionized Air Travel

Jens Flottau January 26, 2023



Boeing 747 (1969, capacity), highly successful

## Airbus A 380 (2005, capacity)

Largest passenger aircraft ever built

BUSINESS | GLOBAL ISSUES

### Airbus A380: End of a multibillion-dollar dream

Andreas Spaeth  
12/16/2021

The last Airbus A380 has been delivered, bringing the program to an end. Once seen as the future of travel, the world's biggest aircraft turned into a flop. But for the plane-maker, it was still worth the effort.

f x



DW Made for minds.

The Airbus A380 story came to an end this week

Source: Airbus A380: End of a multibillion-dollar dream – DW – 12/16/2021

### Why is the Dreamliner so successful?



Boeing 787 (2009, efficiency), highly successful

# The planning triangle.

The integration of the system defines its performance.

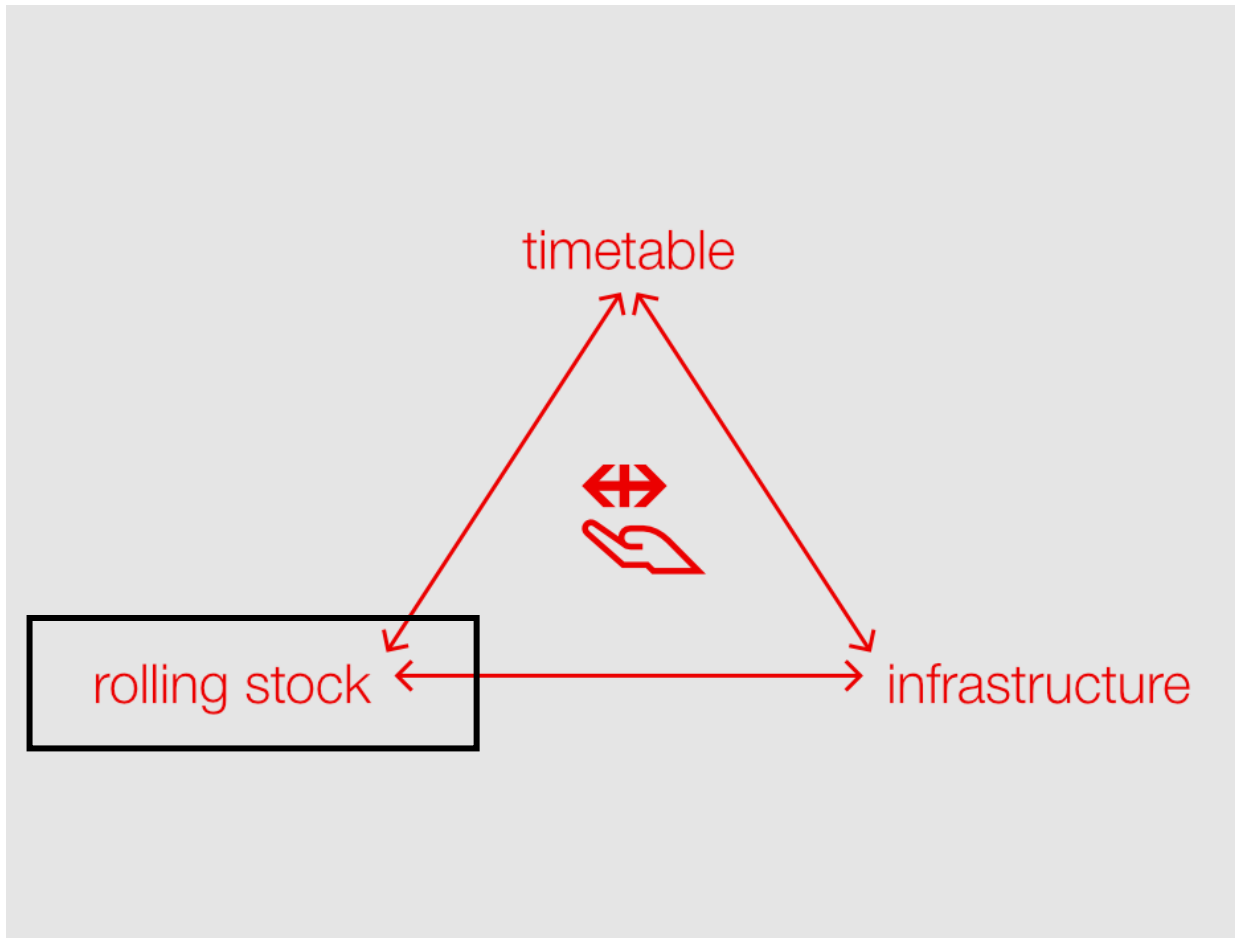

- Today: A «Deep» dive into the **world of rolling stock**.
- Rolling stock as **one of the three elements** of the planning triangle.
- Rolling stock must be a **major element in optimising** the overall railway system ...
- ... **but it is also limited**, as without the other elements, the optimisation of rolling stock might not have the greatest impact on the improvement of the overall system.
- **Efficiency = Integration.**



# 2. Technical aspects.

How does modern rolling stock work?

# Types of train composition (I).

An overview of three fundamental concepts.

Traction    Usage    Traction & usage

Locomotive-carriage

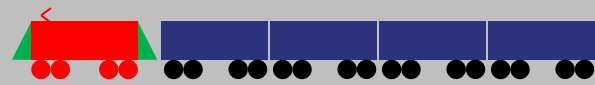

Push-pull train (controller & power trailer)

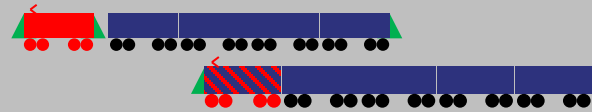

(Electric) Multiple Unit, (E)MU

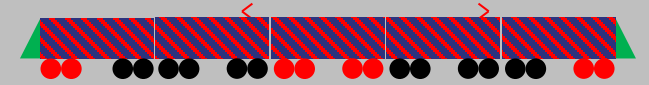

Passenger  
&  
Cargo





# Propulsion systems.

## Advantages and disadvantages.

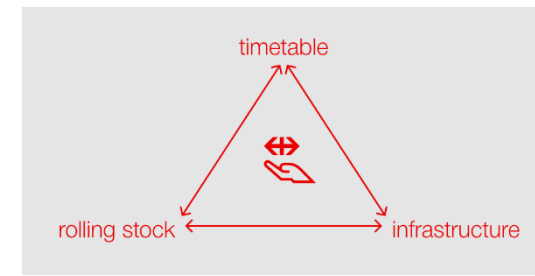

### Electric

- + High energy efficiency
- + Sustainable (source-dependent)
- + No power container required on board
- Electric infrastructure required (catenary)

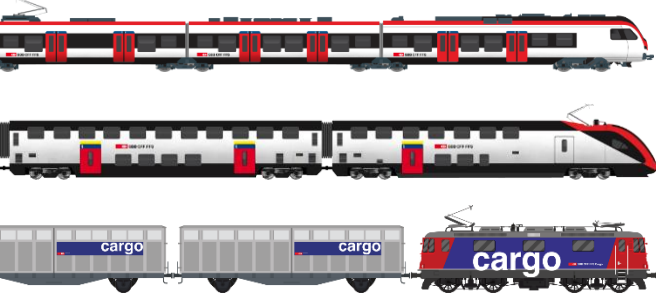

Source: ScienceDirect

### Diesel

- + No line infrastructure needed
- + high volumetric energy density
- Low energy efficiency
- Not sustainable
- Noise and vibration



Source: Bahnonline.ch

### Battery

- + No line infrastructure needed
- + Interoperability with electric infrastructure (catenary)
- + Sustainable (source-dependent)
- + high energy efficiency
- Comparably low range (up to 150 km)
- low volumetric energy density



Source: Akku-Züge



Source: ABB Traction Battery Pro Series

### Hydrogen (fuel cell)

- + No line infrastructure needed
- + Comparably high range (up to 1'000 km)
- + Sustainable (source-dependent)
- + Fast charging (500km in 15min)
- +/- medium volum. energy density
- High cost for train and hydrogen

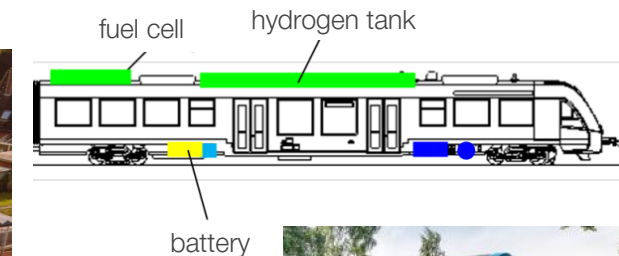

Source: Alstom Coradia iLint

# 3. Rolling stock conceptualisation.

What requirements does rolling stock need to meet?

# Railway Undertaking (RU).

The role you need to understand.



- The Railway Undertaking (RU) is (mostly) the **owner and operator of rolling stock**.
- The RU, like any other company, **sells and produces a product**, which is the transportation of people or goods.
- The RU aims to **fulfil customer needs (Market) ...**
- ... and **while optimising production (Operation)**.
- This fundamental motivation **leads to specific requirements for rolling stock**.



# 3.1 Service design.

What drives service design and why is this defining for rolling stock?





# Service design determines rolling stock. And the trade-offs in its conceptualisation.

Service design

Line capacity

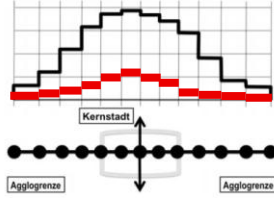

Stopping design

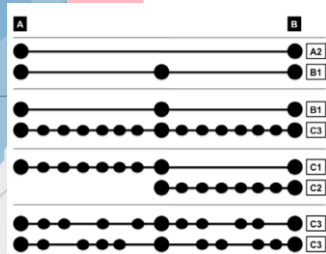

Temporal capacity

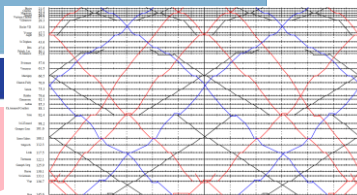
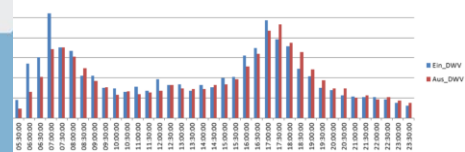

Fernverkehr.

Frequency

Rolling stock conceptualisation



## 3.2 Trade-offs in rolling stock conceptualisation.

What trade-offs do we face in rolling stock conceptualisation? (From why to how).

# What do you want to transport?

Passengers or cargo?

Passengers (we'll come back to later)

- **Move** independently



Cargo

- **Doesn't move** independently



# Cargo rolling stock (Excursus).

Rolling stock is specialized.

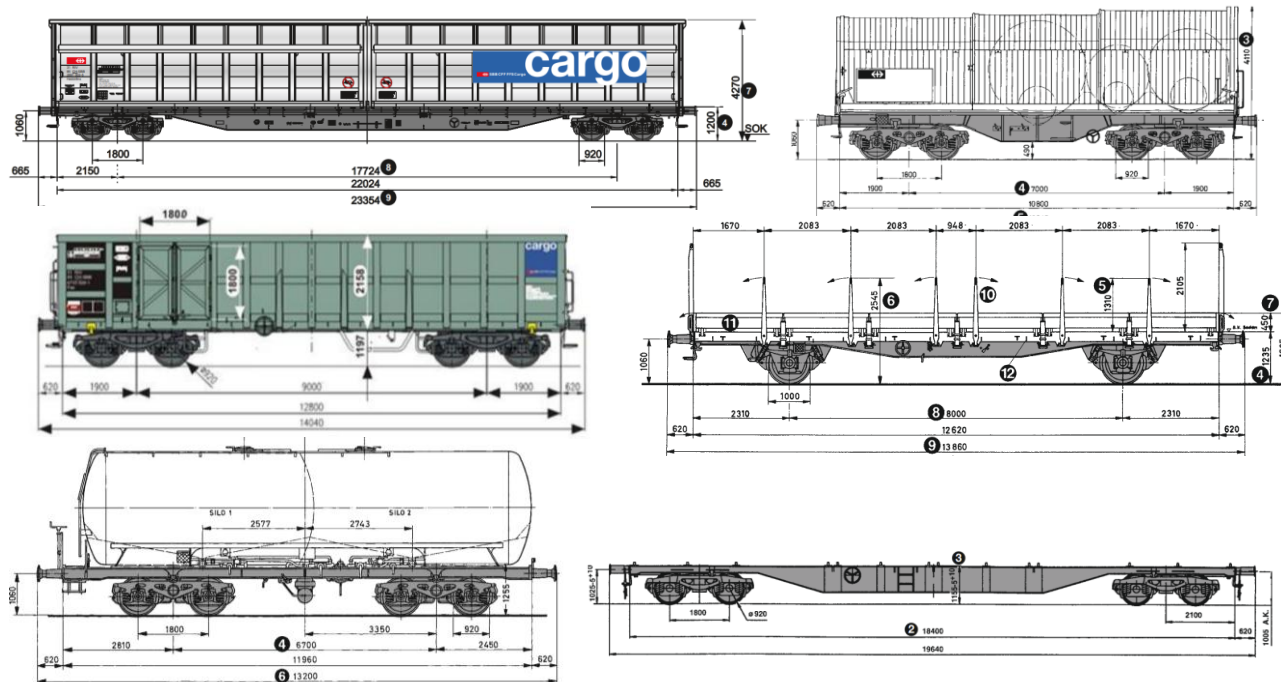
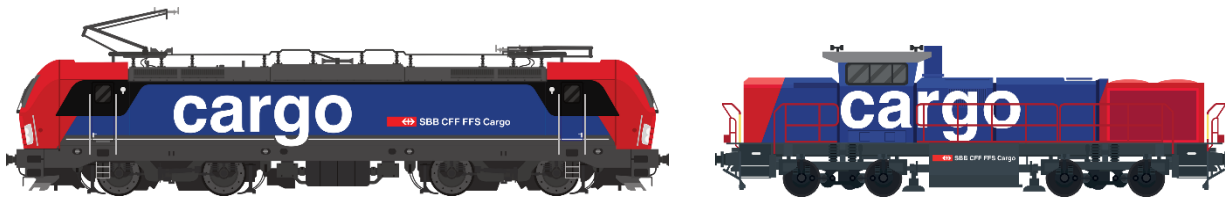

Source: Recherche de type de wagon | CFF

- Only **locomotive-carriage** type trains are used which leads to high shunting effort.
- Cargo rolling stock is highly **dependent on the properties of the goods**, such as solid goods on pallets, solid loose goods (mineral, agricultural products, ...), liquids, bulky items, ...
- Cargo rolling stock is often not owned by the RU, instead, **rental models are widely used, allowing for flexibility in what can be transported** without the need for trade-offs.
- **Shunting locomotives** are required for efficient operation.

# Trade-Offs for passenger trains.

## Levers of rolling stock conceptualisation.

### Technical parameters

- Speed
- Acceleration
- Weight
- Tilting technology

### Processes

- Passenger changing times
- Clearance
- Coupling
- Maintenance
- Cleaning

### Capacity

- Number of floors
- Train length
- Train width
- Seat share 1.& 2. class (or other comfort classes)
- Share of seats and standing place

### Comfort

- Driving comfort (stability)
- Equipment (power outlets, tables, cell phone signal)
- [...]

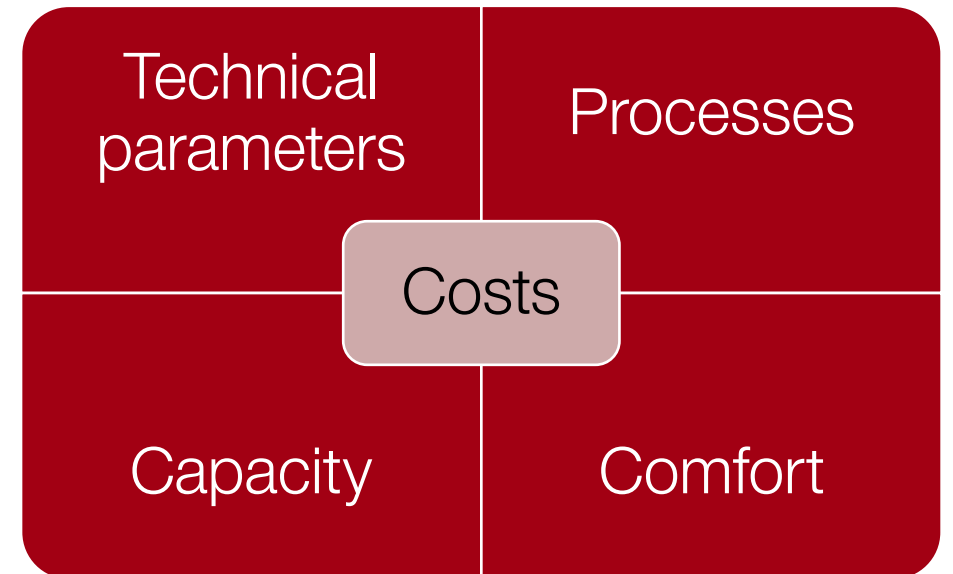

# Technical parameters (I).

## Speed and Acceleration.

<b>ETR 1000 Frecciarossa</b>	<b>V<sub>max</sub> = 350 km/h</b>	<b>Max. Acc. = 0.7 m/s<sup>2</sup></b>
----------------------------------	---------------------------------------	--



Source: ETR 1000 (ETR 400 alias „Frecciarossa 1000“) Hochgeschwindigkeitszüge

<b>RABe 511</b>	<b>V<sub>max</sub> = 160 km/h</b>	<b>Max. Acc. = 1.1 m/s<sup>2</sup></b>
-----------------	---------------------------------------	--



Source: Mein erstes Bild eines Dosto RV zeigt den RABe 511 103 am 22.6.12 bei Gland - Bahnbilder.de

# Technical parameters (II).

## Weight.

Tractive Force (TF) Diagram RABe 511

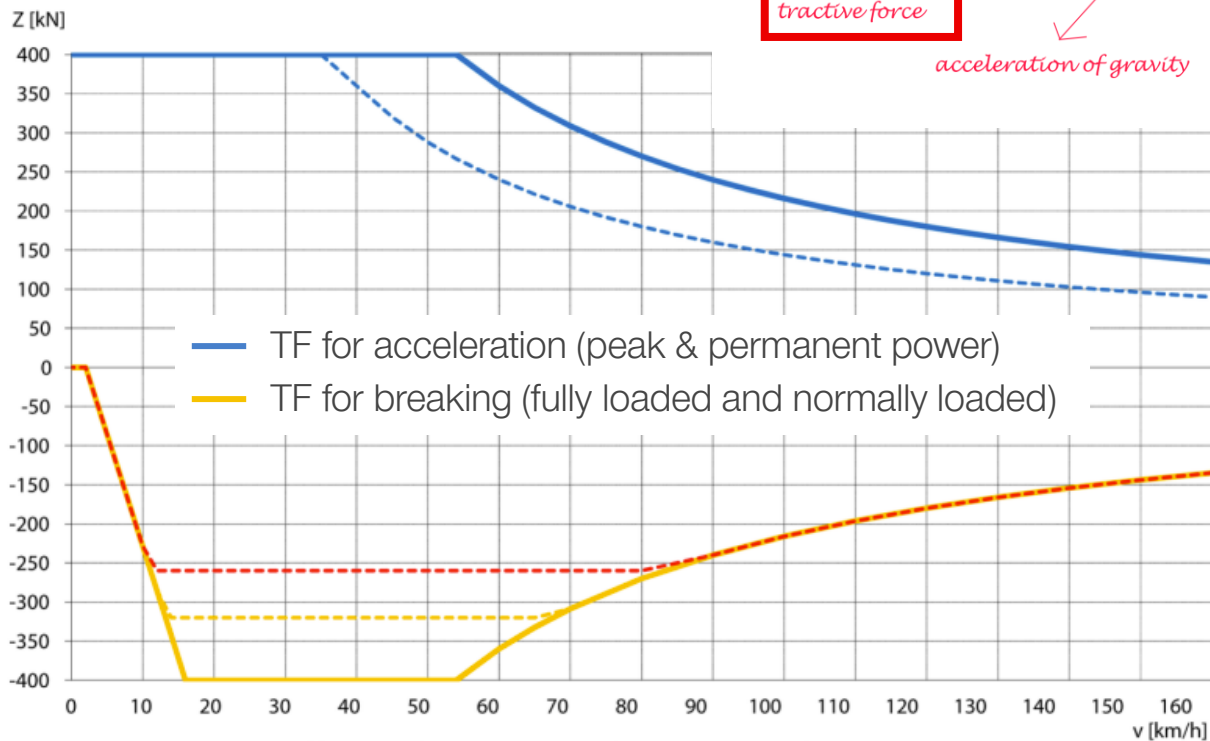

$$F = U_t W = U_t m a_g$$

friction coefficient  $\uparrow$  **weight**  $\uparrow$  mass  $\uparrow$   
**tractive force**  $\downarrow$  acceleration of gravity  $\downarrow$

- **Tractive Force (TF)** is decisive for **acceleration**.
- Tractive Force depends on the **weight of the train** or more precisely, the axle load.
- A **higher weight** results in increased friction, which in turn leads to **higher acceleration**.
- However, it also results in **greater wear on the infrastructure** (trade-off).
- **Tractive Force Diagram (Excursus):** This diagram illustrates the tractive force of a specific train at each speed. In the left part, friction is the limiting factor, while in the right part, it is the engine power.

# Technical parameters (III).

## Tilting technology.

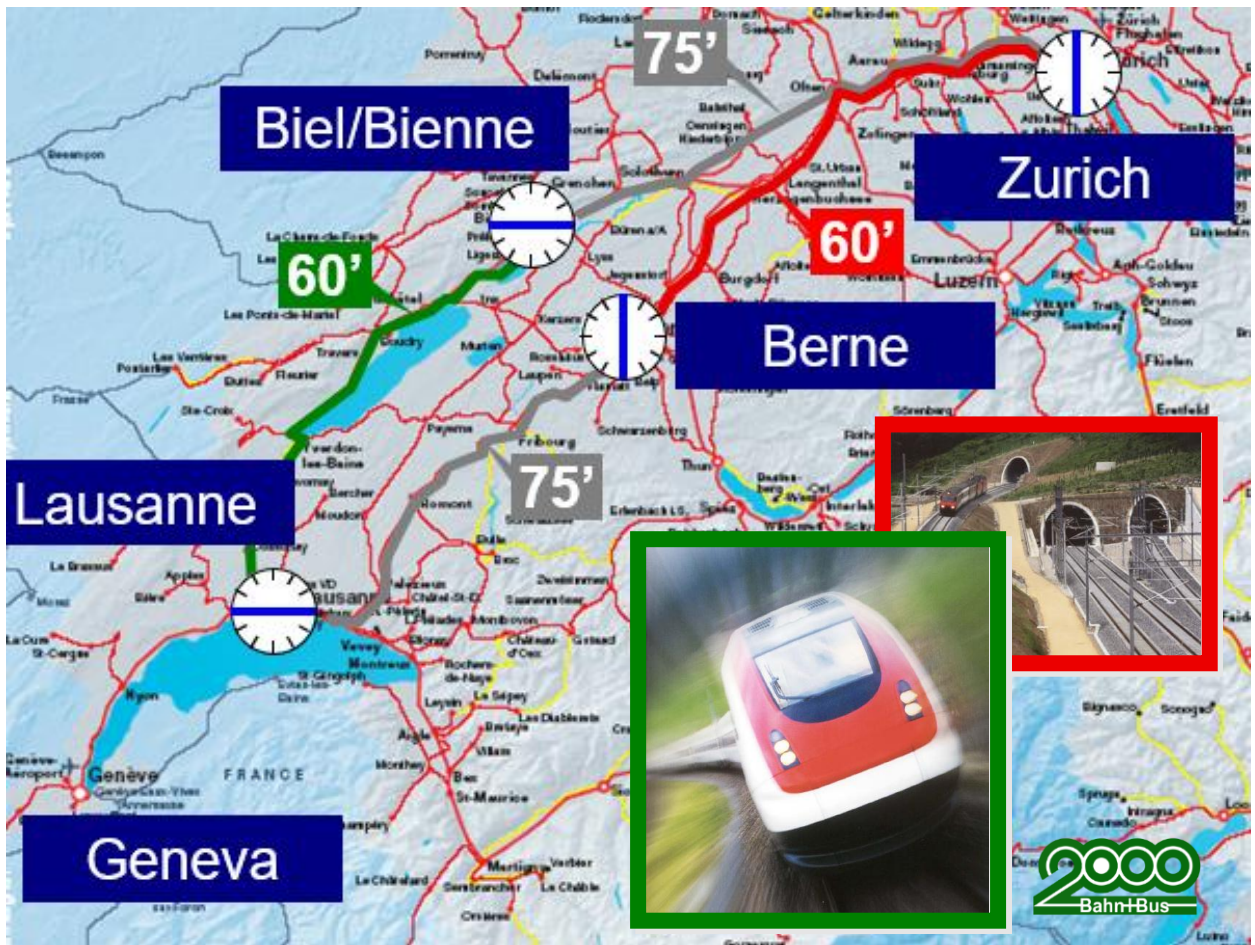

- **Tilting technology** allows for **faster driving speeds on curves**.

- This results in **time savings on existing tracks (green), in contrast to infrastructure investments (red)**.



- An example of **ICN (Inter City Neigezug)** in the context of the «Bahn 2000».

- The goal is «**as fast as required**» (not as fast as possible) to minimise time for the integration into interval timetables.

- This provides a very good illustration of the dependencies within the **planning triangle** (infrastructure, rolling stock and timetable).

# Processes (I).

Passenger changing times and clearance.

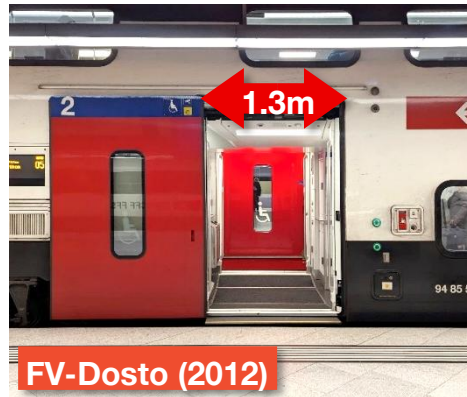
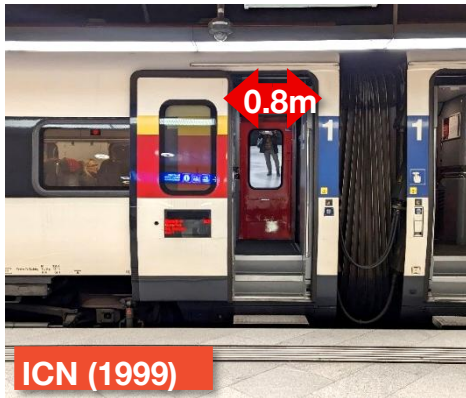

Source: Desiro ML ÖBB Cityjet de

# Processes (II).

## Coupling.



- Current Situation: **Many different coupling systems**, physically and electronically.
- **Screw coupling** has been the standard for over 100 years. This consequently leads to a high shunting effort, especially in the cargo sector.
- Current Processes: **Heterogenous and manually.**
  - Expensive, complex and dangerous.
- Future Processes (ideally): **Standardized and automated.**
  - Cost-effective, simple and safe.
- The **“Digital automated coupling”** project is particularly relevant for the cargo sector.

# Processes (III).

## Maintenance and cleaning.



- **Maintenance and cleaning** are important **process elements**.
- **Every 1-2 weeks** a train undergoes **routine maintenance**, taking from **a view hours up to a day**.
- **Every 1-2 weeks** a train is subject to an **exterior cleaning** process (washing plant).
- The **interior cleaning** is a highly standardised process, typically conducted manually.
- There is an interest in keeping maintenance and cleaning processes **efficient and simple** (time and cost-saving) by the design of rolling stock.

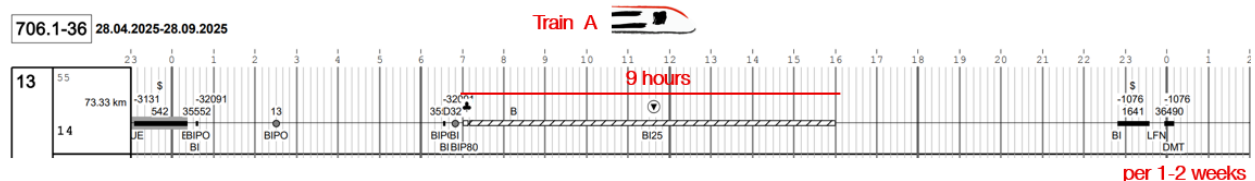

# Capacity (I).

Number of floors, train length and train width.

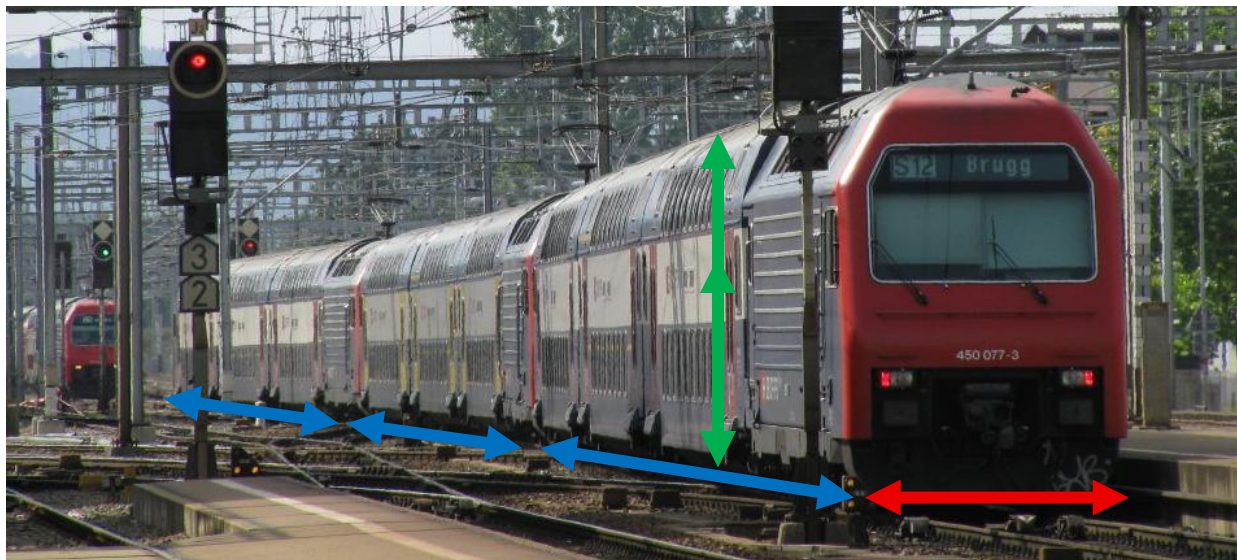
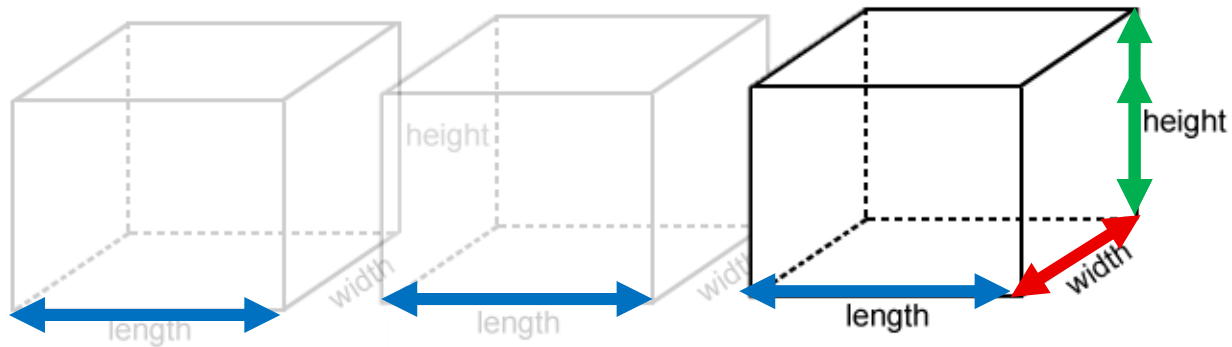

- A train is a «**box**» for transportation where capacity in its simplest form is defined by *height \* length \* width*.
- **Height** is limited by the structural gauge and comes with two distinct options: single-deck or double-deck.
- **Length** is primarily limited by platform length (but also other factors) and can be defined in two ways: The physical vehicle length or the operational length (multiple traction).
- **Width** is constrained by the structural gauge which depends on the track width.
- The «box» will contain **usage space**, but space for **technical components** (traction for example) is also required.
- Usage space can be **optimised for different requirements**.

# Capacity (II).

Seat share 1st/2nd class (or other comfort classes).

61 85 20-90 2xx

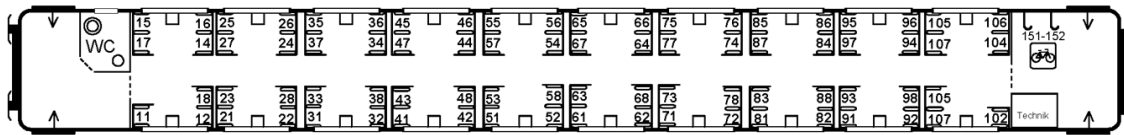

Bpm\_2090: second class, **78 seats per coach**

61 85 10-90 2xx

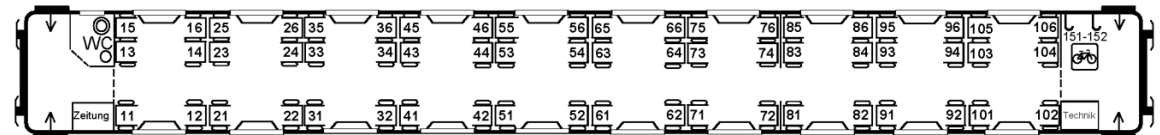

Apm\_1090: first class, **60 seats per coach**



second class, **av. 100 seats per coach** (total 401)

First class, **av. 59 seats per coach** (total 176)



FV-Dosto, RABe 502

# Capacity (III).

Space share seating/standing.



EW IV, long distance traffic



Flirt, regional traffic



Subway, urban traffic

Comfort

Capacity





# 4. Acquisition and life cycle management.

How to acquire and manage the asset?



# Phases of a train's life (Life cycle overview).

## Acquisition and Life cycle management.

**SIEMENS**    **BOMBARDIER**    *Talgo*    **ALSTOM**  
**HITACHI**    **STADLER**    **CRRC**    **CAF**

**Stadler will manufacture FLIRT Evo trains for Switzerland**

27.05.2024

Stadler, a Swiss train manufacturer, has received an order from the Swiss Federal Railways (SBB) for 33 new FLIRT Evo trains for cross-border transportation, this is reported by the railway transport news portal [Railway Supply](#).



Source: Stadler will manufacture FLIRT Evo trains for Switzerland - Railway Supply



# 4.1 Acquisition.

Why is it a special market and a strict process?

# Rolling stock market.

## An oligopoly with its specialities.

Global rolling stock market is expanding; the top ten manufacturers control 70%



Top 10 manufacturers based on new rolling stock revenue 2024 <sup>1</sup>  
(EUR billion<sup>2</sup>)

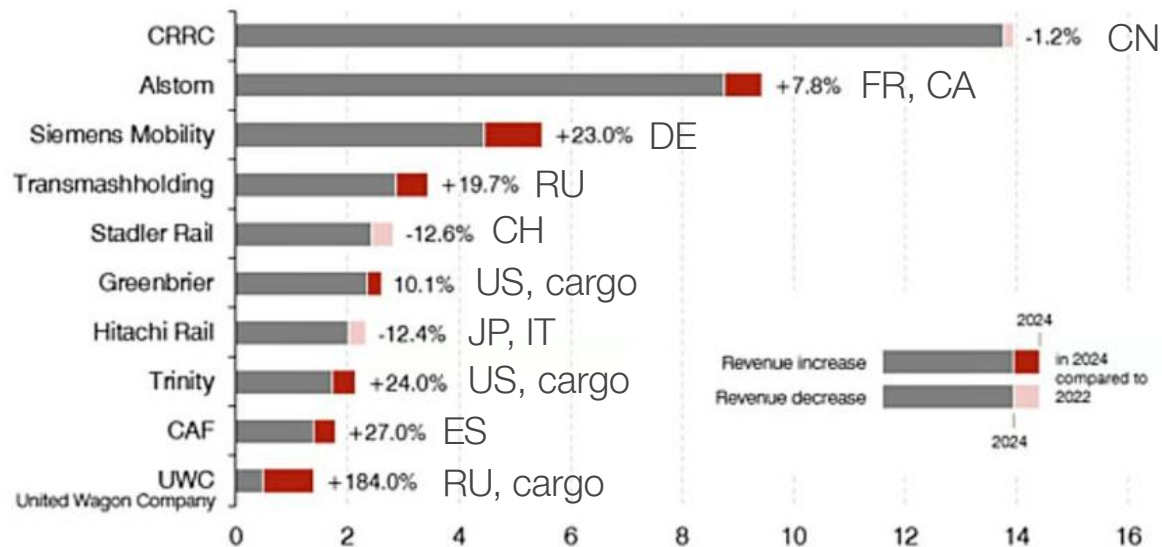

Global rolling stock market is expanding | Latest Railway News

<sup>1</sup> Revenue from new rolling stock is partially estimated. Revenues from companies whose fiscal year ended in the first half of 2025 have been allocated to the year 2024.

<sup>2</sup> Currencies were converted into EUR using the average annual exchange rate for the respective period.

- The rolling stock market is an **oligopoly** (characterised by a few manufacturers).
- The industry faces **high entry barriers** (including capital, specialised knowledge, and time constraints).
- The **expected demand** for rolling stock in Central Europe is **higher than the expected supply**.
- The market is **nationalised**; with observable tendencies towards protectionism.
- The **availability of specified products** is limited, which results either in a restricted range of options or a significant engineering effort if a train needs to be highly specialized.

# Acquisition Process.

Public call for tenders mandatory by law.

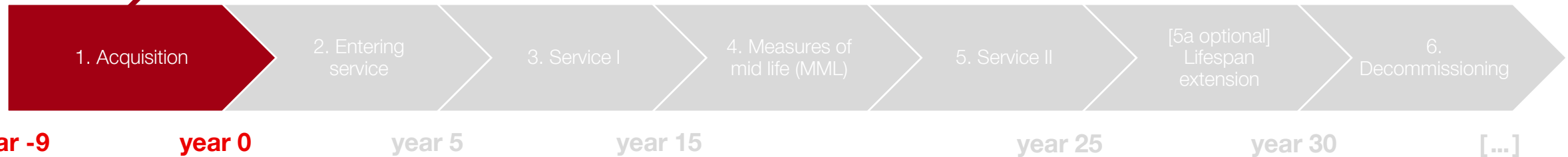
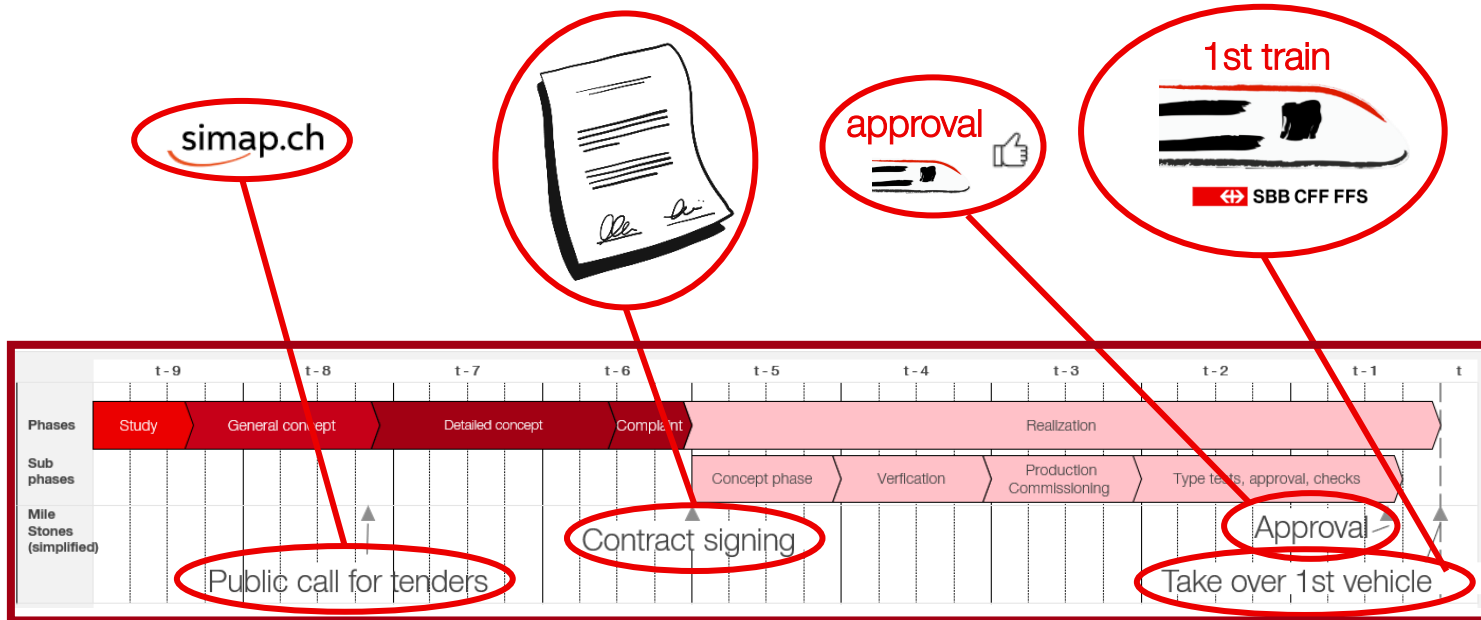

- **A public call for tenders** is mandatory by law (simap.ch).
- The RU defines the **requirements for the train**.
- There is a **lack of limited participation by manufacturers**, which could result in no contract or being «forced» to take the only offer.
- The **process concludes** with the approval and **the delivery of the first train to enter service**.

# Acquisition (Flirt Evo: Example I).

Regional train, single deck, Vmax= 160km/h.

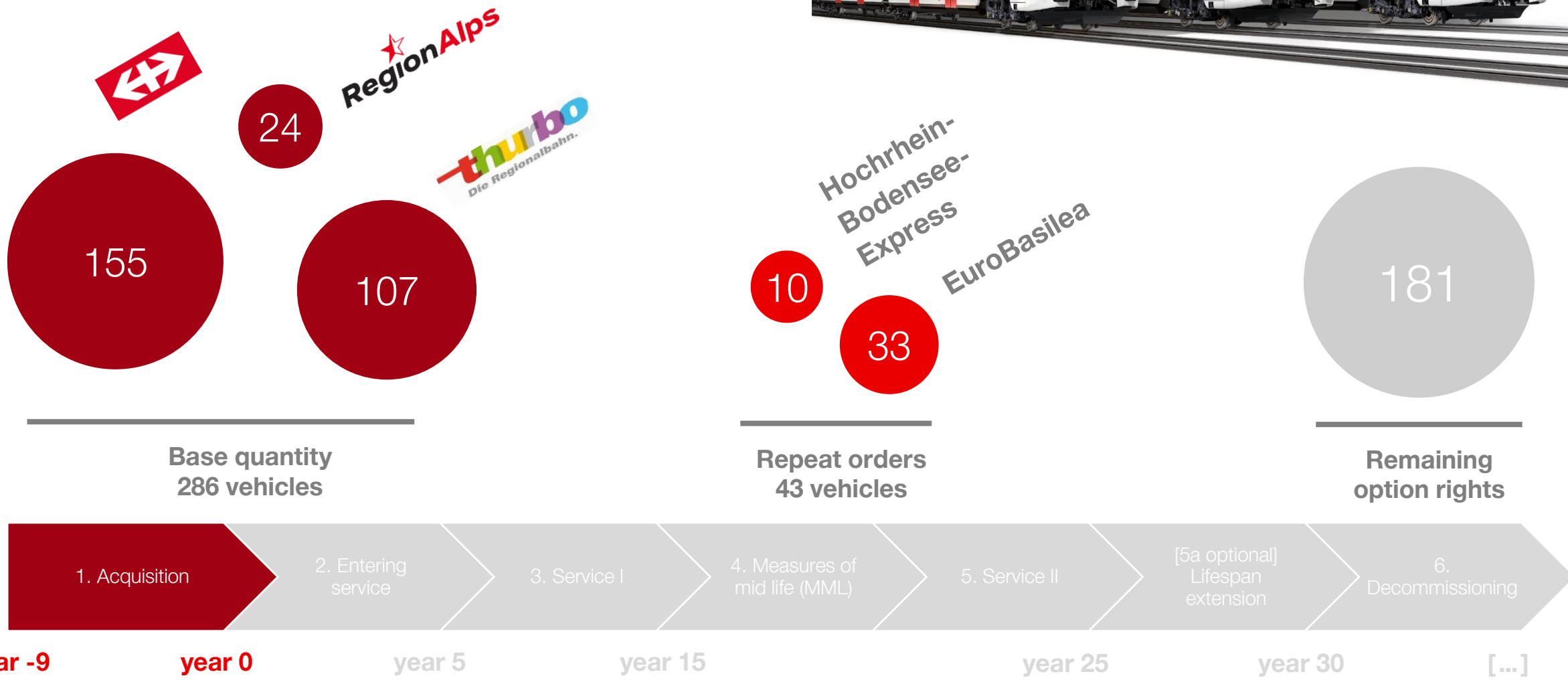

# Acquisition (Flirt Evo: Example II).

## Homogenisation of fleets.

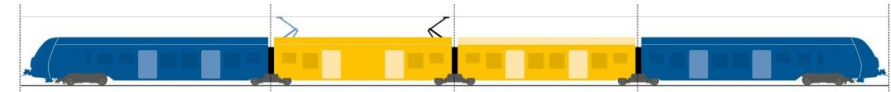
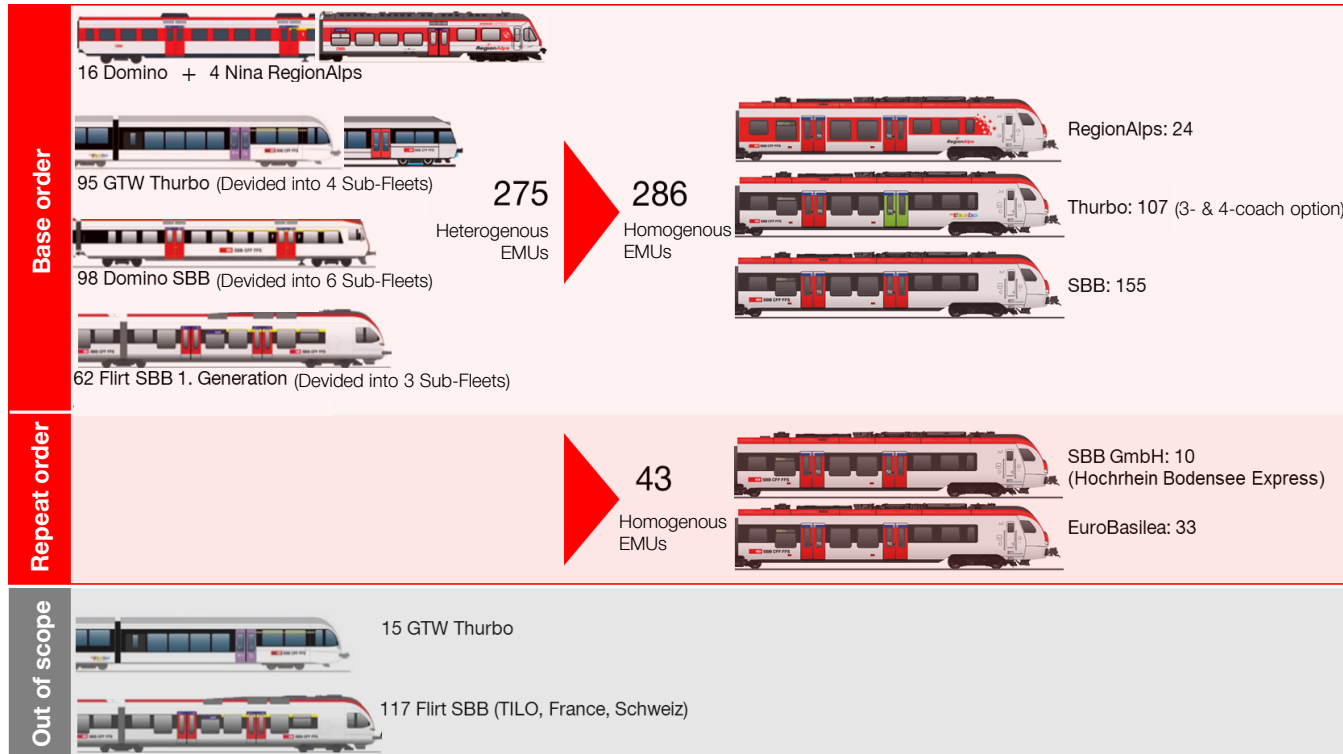

# Acquisition (Flirt Evo: Example III).

## Strategic goals.



**Prio 1.** Multiple units fulfil the vehicle concept resulting from the expansion steps (including journey times, stopping times and capacities).



**Prio 2.** Multiple units are based on a platform vehicle that has been developed and tested in operation and is ideally already in use in Switzerland, Germany and/or Austria.



**Prio 3.** Multiple units will be available for commercial use in the required quantity and quality from December 2025 and will support the planned renewal of concessions.



**Prio 4.** Investment and operating costs must not exceed the value of the end-of-life vehicles being replaced.



**Prio 5.** Customers benefit from modern, reliable and cost-effective rolling stock.



# Acquisition (Flirt Evo: Example IV).

Minimization of technical innovation for risk reduction.



Natural cooling substance

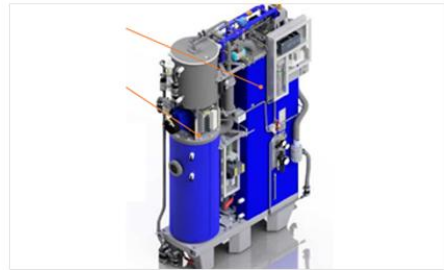

Water treatment installation with distillation of wastewater

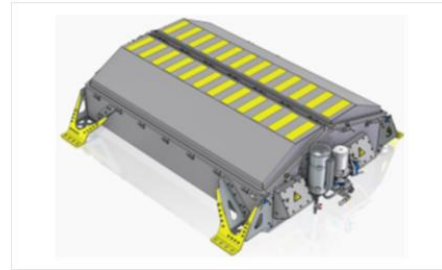

Energy-efficient converter and main transformer on the roof

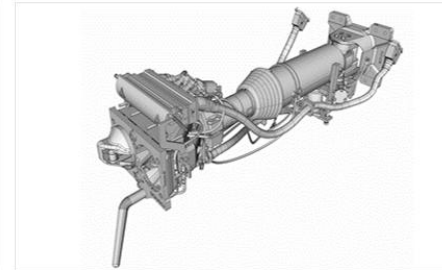

Estandardised coupling (Scharfenberg Type 10)



ETCS system GUARDIA (ETCS baseline 3 Release 2) for operation at level 0,1,2 and partially PZB



TIMS as a customer information system



New concept of the multifunctional zone

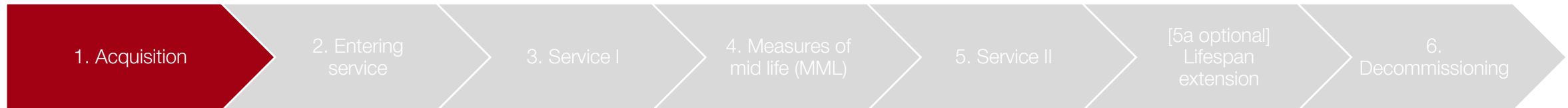

year -9

year 0

year 5

year 15

year 25

year 30

[...]

# Acquisition (Flirt Evo: Example V). Maquette.



# Acquisition (Flirt Evo: Example VI).

## Type tests.



# Acquisition (Flirt Evo: Example VII).

Proof of maintenance and training.

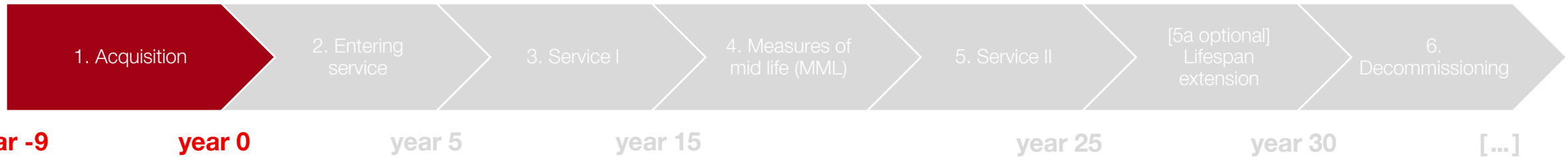
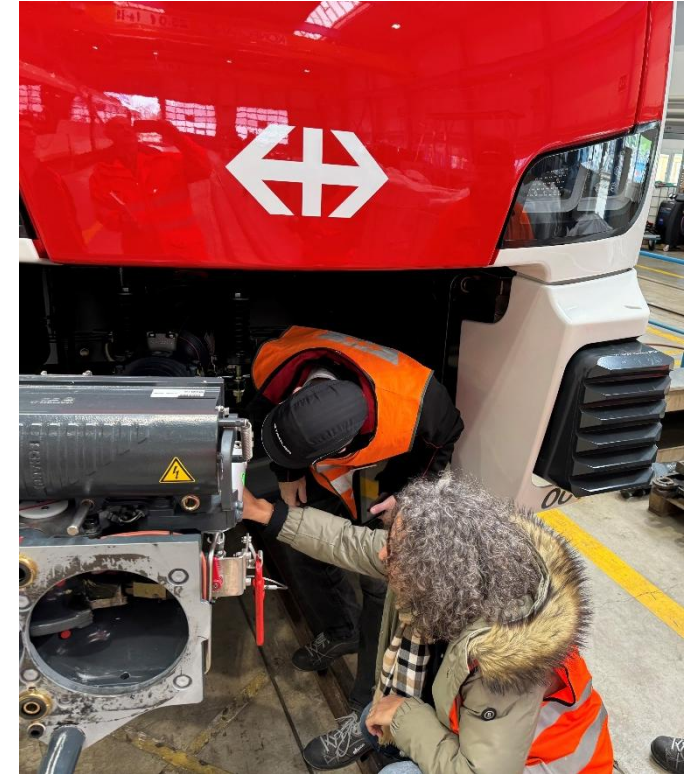
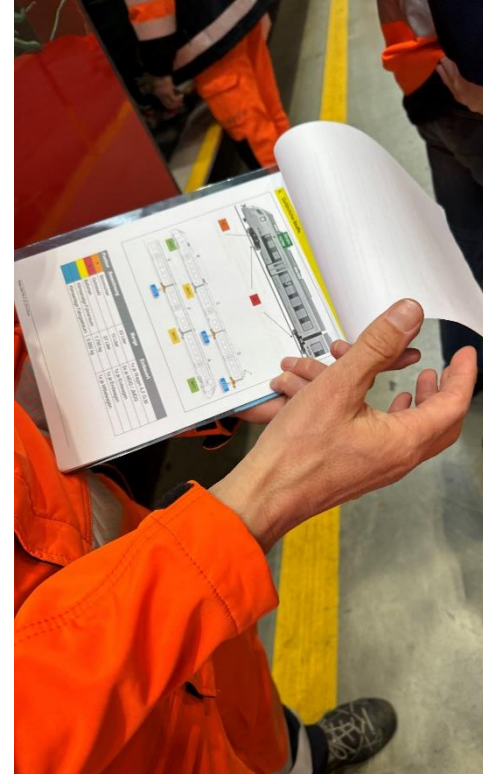
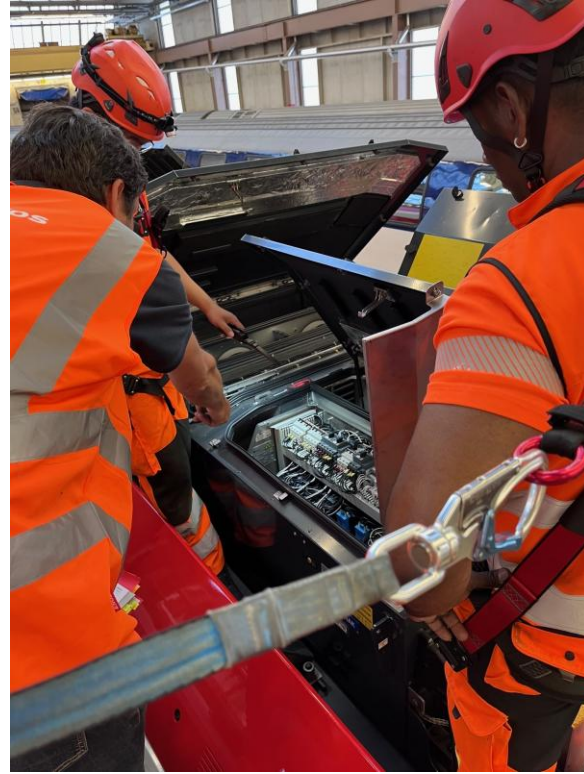

# Acquisition (Flirt Evo Example VIII). Media events.



# 4.2 Life cycle management (LCM).

How to manage the whole life cycle?

# Why LCM?

Optimization throughout the whole life cycle.

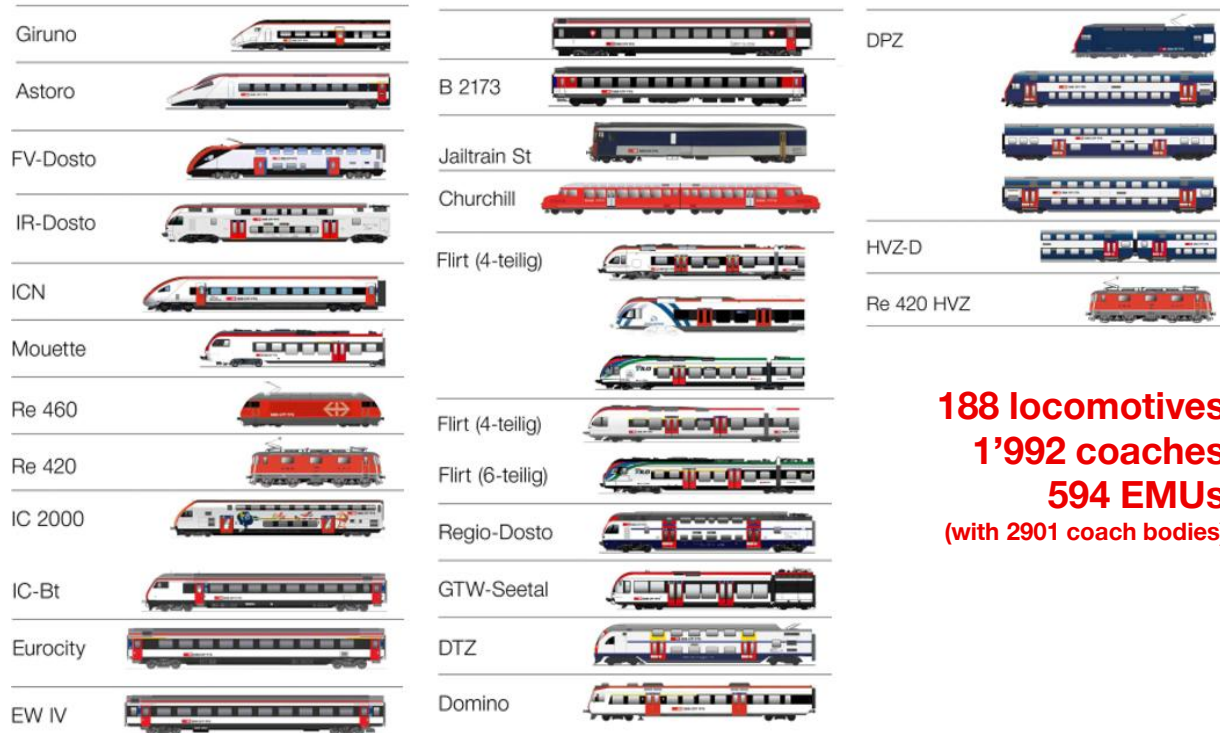

**188 locomotives**  
**1'992 coaches**  
**594 EMUs**  
*(with 2901 coach bodies)*

- The **acquisition cost (purchase price) accounts for only around 20% of the overall costs incurred** throughout the entire life cycle of a rolling stock asset.
- Rule of thumb: At the time of acquisition
  - only 20% of costs are incurred
  - while 80% of costs are determined
- Goal: Optimisation of **costs, benefit and risks throughout the whole life cycle.**
- **Synchronization across fleets** as seen with the numerous vehicles of different types and ages in the SBB passenger RU.

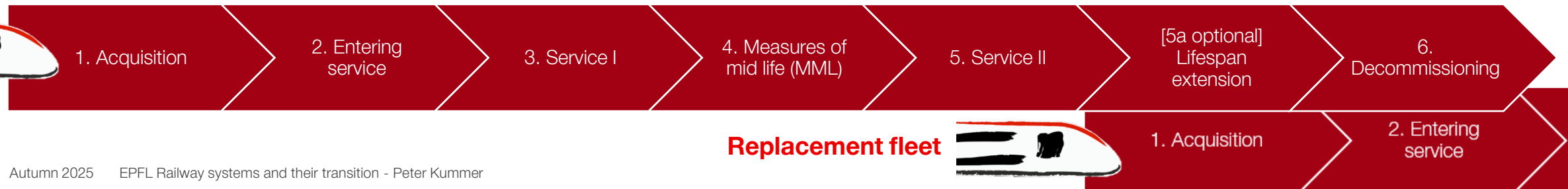

# Entering Service.

## FV-Dosto example.

### SBB to abandon roll compensation technology on FV-Dosto fleet

The technology is expensive to maintain and has caused passenger complaints.



- Goals:
  - Bring **all vehicles into service** with the expected performance.
  - Verify all **contract terms** (deficiencies and warranty).
- Challenges:
  - Adaptation to «**teething troubles**».
  - **Education** of operating staff (documentation).
  - Resources for the **takeover of all vehicles**.
  - **Maintenance** during the first three to five years by the manufacturer.



# Entering Service. FV-Dosto example.

## Blick

Des bactéries surchargées

### Certains trains CFF vont sentir l'excrément pendant des mois encore

Les trains des CFF continuent de dégager des odeurs de matières fécales. Cela fait déjà des mois que les passagers sont confrontés à ce désagrément. Certains politiciens montent désormais au front.

Publié: 05.10.2022 à 10:38 heures | Dernière mise à jour: 05.10.2022 à 16:15 heures

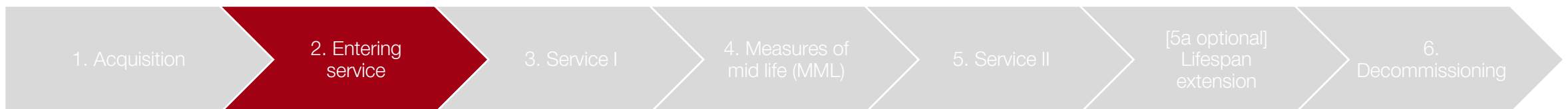



# Service I/II.

## RABe 511 example (RV-Dosto).

Mission statement RABe 511 RV  
*“Cost-efficient operation with high availability”*



- Goals:
  - Achieve performance at the best possible level of service («**working horse**»).
  - **Optimize maintenance** and other cost-driving factors.
- Challenges:
  - **Obsolescence** of systems (no further availability).

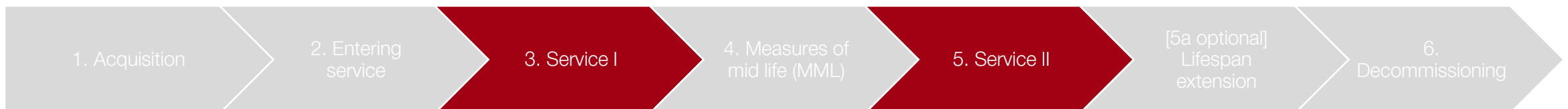
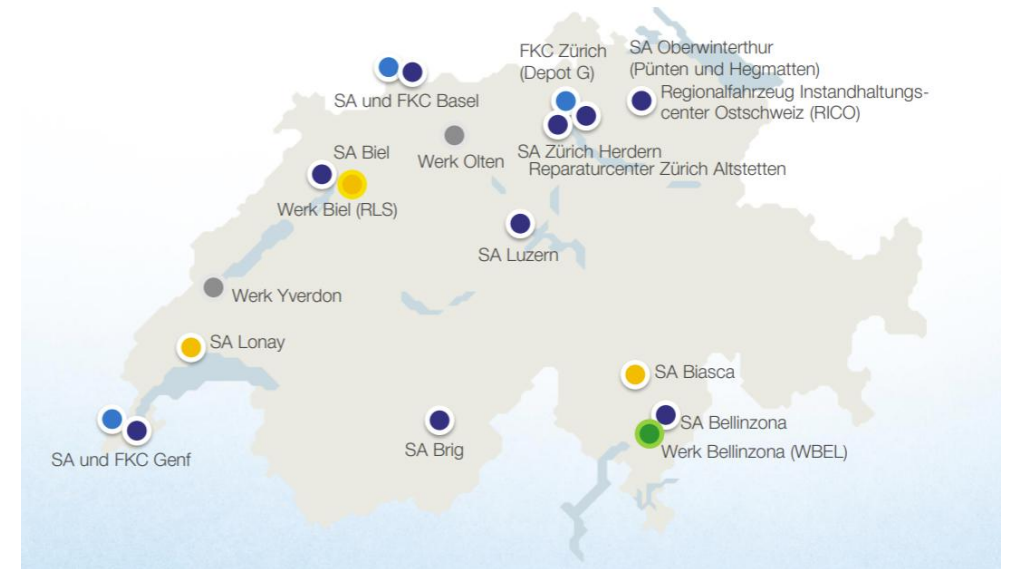
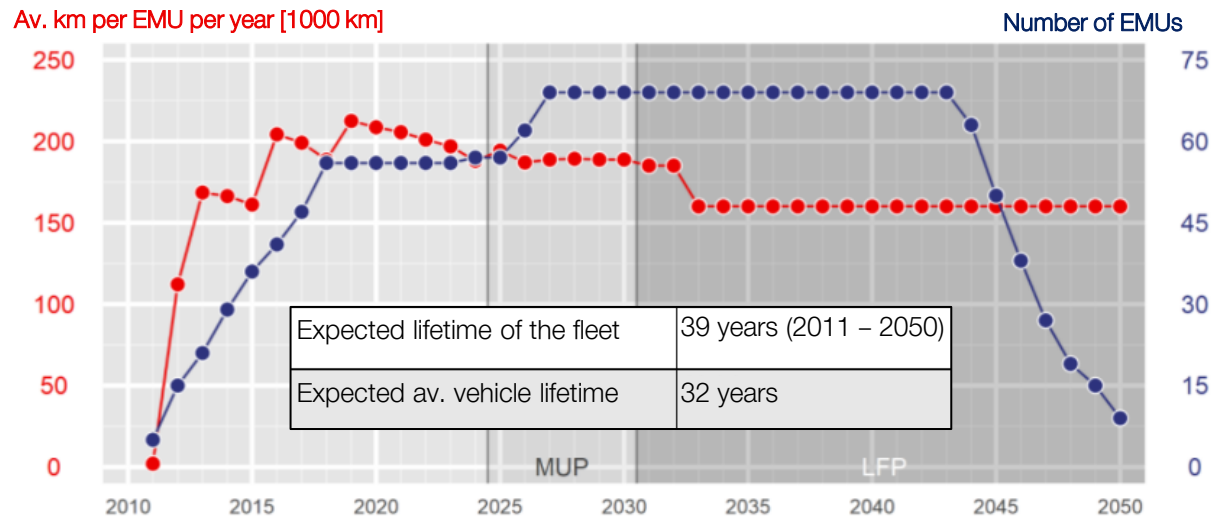

# Measures of mid life (MML).

## RABe 511 example (RV-Dosto).



- Goals
  - **Readiness for the second service period.**
  - Determine decommissioning.
- Challenges
  - **Corrosion remediation.**
  - Technical **weaknesses and obsolescence** of systems (no further availability).
  - **Upgrade to customer expectations** (comfort, interior).

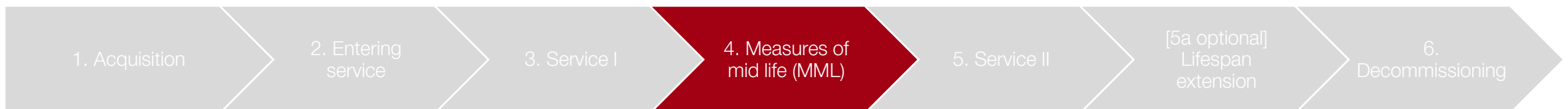
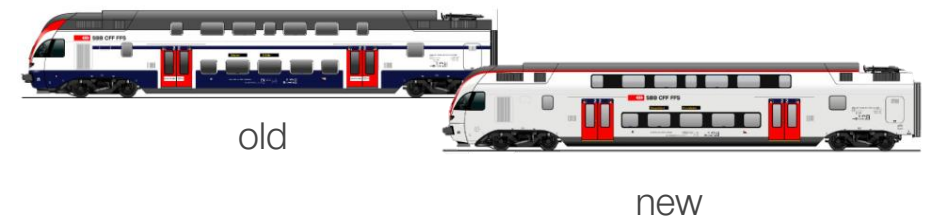

# The life expectancy of trains decreases (Excursus). MML instead of modernizations.

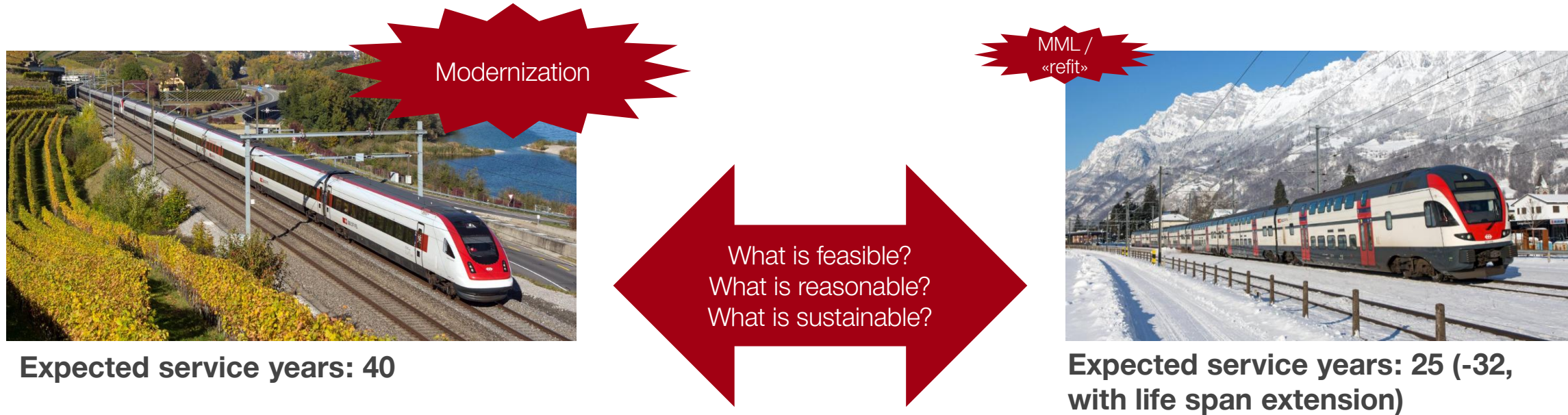

**Technical Complexity**  
**Speed of technological development**



Source: [Entwicklung des Volkswagen Golf : r/Volkswagen](https://www.r/Volkswagen)

# Life span extension and decommissioning. EW IV example.

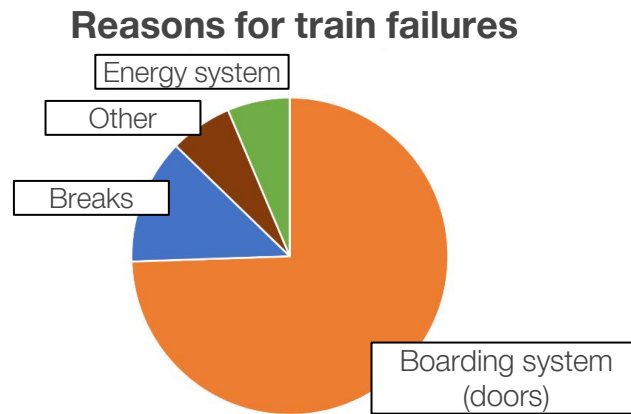
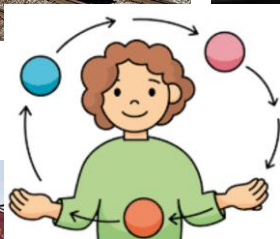

- Goals:
  - Achieve the best **LCM efficiency**.
  - Ensure seamless **fleet replacement**.
  - Optimise the **decommissioning process**.
- Challenges:
  - **Predictability** of replacements.
  - Determining what and when to do **investments in old vehicles?**
  - «Uncomfortable surprises».

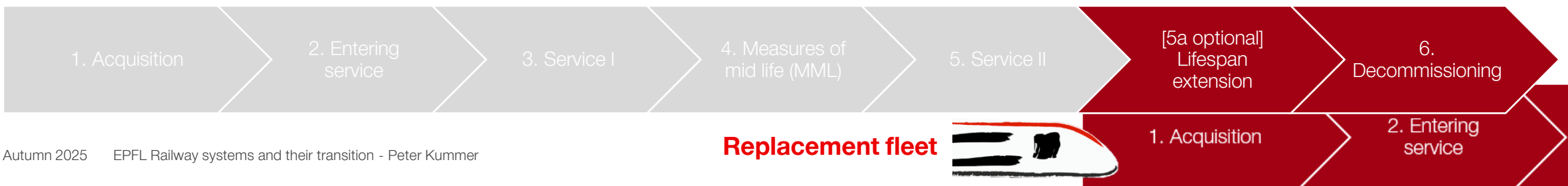



# 5. Conclusion.

What to take away?

## Take-away messages.

1. **Rolling stock is part of the planning triangle** (which includes service and infrastructure). The performance of the overall railway system depends on efficiency and integration of rolling stock.
2. The elements of service design, particularly line design, stopping design, line demand, temporal dependencies and frequency lead to **specific requirements** for rolling stock.
3. The requirements for rolling stock **set the «levers»** in technical parameters, processes, capacity and comfort when conceptualising a train.
4. The acquisition of rolling stock is influenced by **a unique market situation (oligopoly)** and a process regulated by law (public call for tenders).
5. **The overall costs and expenses extend well beyond the initial acquisition.** The entire life cycle of a train comprises many phases, all managed through life cycle management (LCM).



Thank you!

# 6. Case study.

How would you conceptualise a train for TILO?

# TILO (Treni Regionali Ticino Lombardia) is in need for a new train.

## Description of the current situation.



- TILO (Treni Regionali Ticino Lombardia) is an RU that operates cross-border regional services in the canton of Ticino and the Italian region of Lombardy. It is jointly owned by SBB and Italy's Trenord, with each holding a 50% stake. Its headquarters are in Bellinzona.
- Demand for the TILO network is developing positively. By 2050, demand across Switzerland is expected to develop by an average of +35%. The RUs currently operate 383 connections a day on the network and aim to increase this to 478 connections in the future (+95 connections, +25%). To achieve this, TILO requires new rolling stock to implement the expansion of its services. The existing rolling stock, consisting of 40 Flirt SBB RABe 524 (23 of which are 4-parts and 17 are 6-parts) will continue to be in operation.
- Customer feedback has been largely positive. Passengers are pleased that investments are being made in rail services in the canton of Ticino and in the border region of Lombardy. However, they hope that delays will also be reduced and that trains will provide more space during busy periods.

# TILO (Treni Regionali Ticino Lombardia) is in need for a new train.

## Task description.

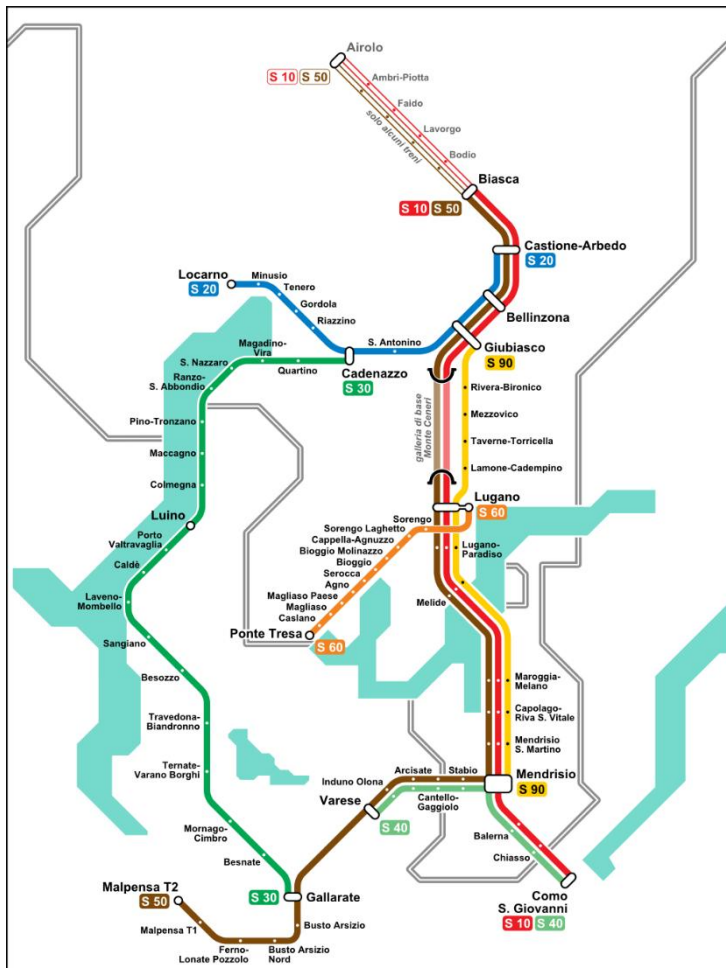

Source: Mappa rete celere ticinese - S-Bahn Tessin - Wikipedia

- Setting:
  - You are the project manager(s) of the acquisition project as an employee of the RU TILO.
- Boundary conditions:
  - The trains must be capable of operating the specified services (illustration), in addition to S60 (narrow gauge).
- Tasks:
  1. Define **strategic goals** for the acquisition project.
  2. **Conceptualise** the new train systematically for the public call for tenders (what do you expect from the manufacturer? What requirements has the train to meet? How many do you need?). Justify your decisions and present your solutions adequately.
  3. Identify challenges regarding **infrastructure and interoperability** (relation to week 3).
  4. For the motivated: Investigate the rolling stock market **to identify one or more potentially suitable products** that meet your requirements.

# TILO (Treni Regionali Ticino Lombardia) is in need for a new train. Helpful information and tips.

- Your work should focus on Task 2 (Conceptualisation) which means at around 2/3 of the overall effort.
- The challenge in this task is to
  - First: Ask the right questions (which requirements do we need to define?)
  - Second: Find the right answers (how do we define the requirements?).
- The content of this week's lecture (as well as the previous lectures) will assist you in fulfilling the tasks. However, you are encouraged to extend your view by internet research.
- Qualitative or relative definitions of requirements are mostly sufficient. However, try to be as specific as possible.
- Acquisition projects typically consist of three roles:
  - Overall manager
  - Commercial manager
  - Technical manager
- Links
  - [OpenRailwayMap.org](https://www.openrailwaymap.org)